

HYDRA PLATFORMS

Self-Erecting, Self-Propelled, Under-Bridge
Aerial Access Platforms

SPECIFICATIONS FOR TRUCK MODEL HPT 16/52

HPT 16/52 Specs.	English	Metric
Platform Length	52 ft	15.85 m
Platform Width	3 ft 8.5 in	1.13 m
Platform Weight Capacity	1,400 lbs.	635 kg
Vertical Height Clearance	7 ft 8 in	2.3 m
Max. Lowering Depth	22 ft	6.7 m
Platform Rotation	180°	180°
Tower Separation Width	7 ft 8 in	2.3 m
Unit Length	38 ft	11.6 m
Unit Width	8 ft 2 in	2.45 m
Unit Height (transport pos.)	13 ft 5 in	4.1 m
Total Weight (approximate)	48,000 lbs.	21,772 kg
Hydraulic Pressure	2,800 psi	2,800 psi

- ▶ Two inboard hydraulic stabilizers
- ▶ Self-propelled by hydrostatic drive
- ▶ 5-minute, self-erecting in single lane
- ▶ Main hydraulic system; P.T.O. or diesel engine gen. set pump drive
- ▶ Auxiliary hydraulic backup system; truck engine P.T.O. pump drive
- ▶ Towers 5° over center swing
- ▶ Controls units on platform and deck
- ▶ Voice communication system; platform to deck
- ▶ Optional diesel gen. set fitted (or as specified)

The most versatile under-bridge device for bridge inspections and under-bridge operations.

The Hydra Platform truck mounted model HPT 16/52 is a comprehensively equipped under-bridge access and work platform, mounted on a diesel powered truck, supplied with an optional silenced 20/30 KW diesel generator set, 110/220 volt, is suitable for power tools & job site lighting.

- ▶ State-of-the-art under-bridge access platform
- ▶ #1 in the U.S.A. - Tested the Best
- ▶ 18 year 100% safety record
- ▶ Meets all OSHA / ANSI / SIA safety codes
A92.2/1990 + A92.8/1993
- ▶ 2 separate hydraulic erection systems
- ▶ 16 m (52 ft) platform length
- ▶ Patented Tower Separation System
- ▶ 180 degree platform rotation
- ▶ 1,400 lbs. (635 kg) platform capacity
- ▶ Truck specs available upon request

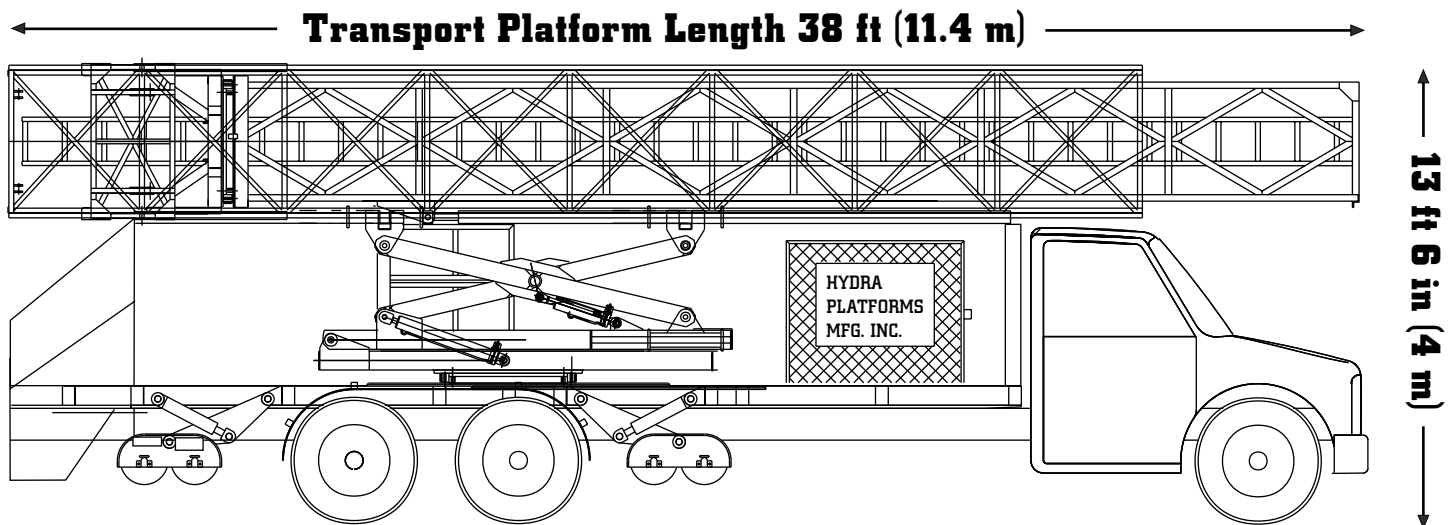

To reflect design improvements, specifications are subject to change without notice. All measurements, weights, etc. stated are approximate. Call for details.

Hydra Platforms MFG., Inc.

P.O. Box 5280 Lake Wylie South Carolina, 29710 USA

Phone: 803.831.8195 Fax: 803.831.0606 Web: www.HydraPlatforms.com